

HERBOLD

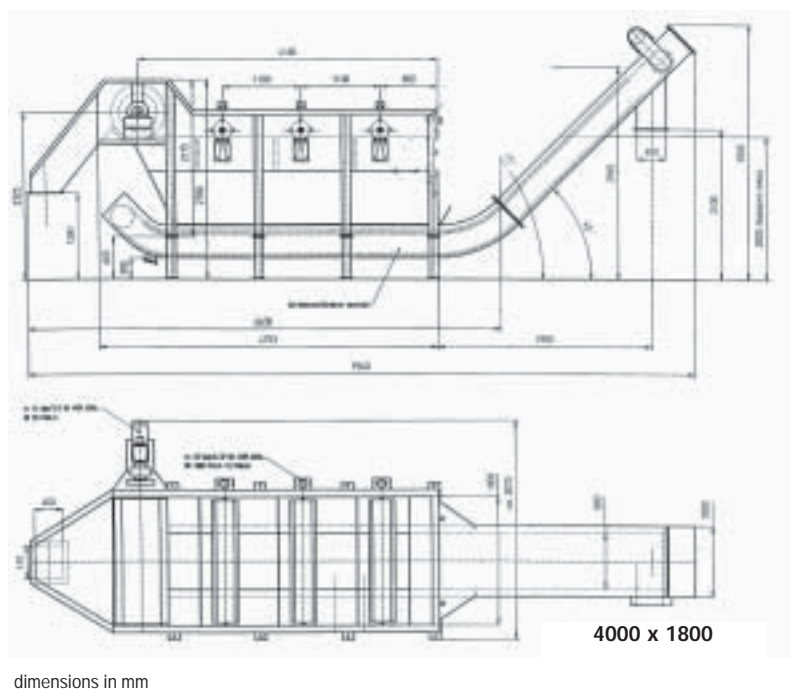

Separation tank (Swim-sink)

Swim-sink tanks use the different specific weights of the various kinds of plastics to separate them. Typical applications are the separation of PET or PVC (both sink) from polyolefines, such as PE or PP (both of them swim). The light fraction is transported along the surface of the water by means of paddle drums to a discharge conveyor; the heavy fraction are extracted – depending on its amount – either by a pair of pneumatic valves at the bottom of the tank or by a scrape conveyor mounted below the tank.

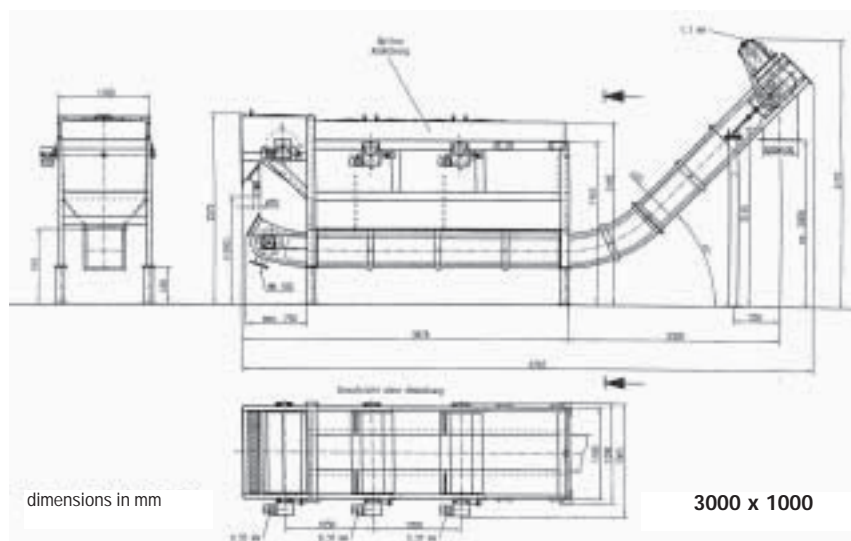

Technical data:			
Separation tank	2900 lg. x 1000 mm	3000 lg. x 1000 mm	4000 lg. x 1800 mm
Drives (kW)			
2 transport drums	0.74 (0.37)	0.74 (0.37)	---
3 transport drums		---	1.1 (0.37) kW
1 Discharge drive		1.1	3.0
Total power of drives (kW)	3-4	6-8	8-11
Discharge with scraping			
chain conveyor	N/A	Incl.	Incl.
Throughput (t/h)			
Hard plastic	1.5-2.5	1.5	2.5 (HDPE)
Film	250	0,5-0,8	0,8-1.2 (LDPE)
PET flake	1.5	1.5	3.5

Special features:

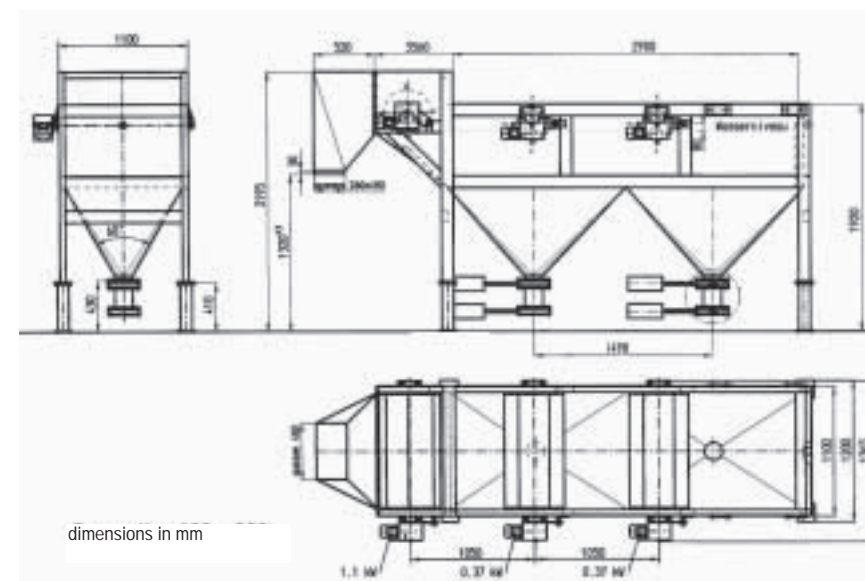

Our product range

- Granulators
- Pulverizing Systems
- Shredders
- Hammer Mills
- HOG Shredders
- Guillotines
- Washing Systems
- Plastcompactors

Specifications are not binding and subject to change without notice. Edition 12/2004



Herbold Meckesheim GmbH
 Industriestr. 33
 D-74909 Meckesheim
 Postfach 1218
 D-74908 Meckesheim
 Tel.: + 49 (0) 6226/ 932- 0
 Fax: + 49 (0) 6226/932-495
 E-Mail: Herbold@Herbold.com
 Internet: www.Herbold.com

Our US-Subsidiary:
Resource Recycling Systems Inc.
 333 George Washington Highway,
 USA-Smithfield,
 Rhode Island, 02917
 Phone: + 1 401 232 3354
 Fax.: + 1 401 232 5425
 info@resourcerecycling.net
 www.resourcerecycling.net